

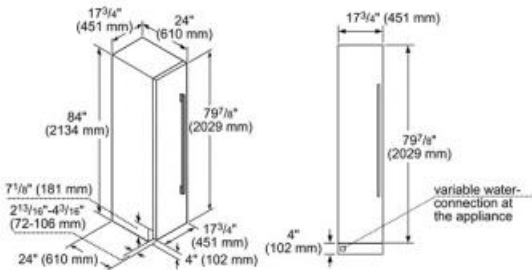

Performance

- Dedicated compressor and evaporator
- Electronic controls for precise temperature management
- Full length cantilever racks for ultimate adjustability
- Full Width Metal Freezer Shelves
- Full extension drawers at 90° door opening angle
- Oversized Freezer Basket
- Discrete and filtered ice-maker
- Ultra capacity ice drawer
- SuperFreeze - Freezes food quickly
- Sabbath mode
- Economy mode
- Vacation mode
- Door open alarm
- ENERGY STAR® Qualified
- 8.6 Cu. Ft.

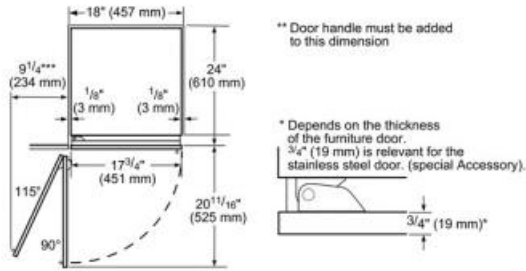
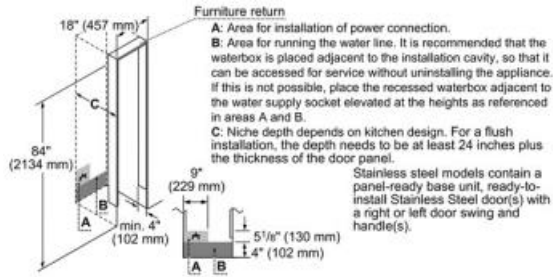

Amps (A)	10
Frequency (Hz)	60
Approval certificates	ETL, ETL C
Plug type	120V-3 prong
Net weight (lbs)	263
Gross weight (lbs)	291
Refrigerator gross capacity (cu.ft.)	0
Freezer gross capacity (cu.ft.)	9
Number of compressors	1
Optional accessories	FRAMEKIT10, HEATRKIT10, MS36HNDL10, PR36HNDL10, REPLFLTR10, SCRNFLTR10, TCH18IR800, TFL18IR800
Number of door bins - freezer	5
Number of shelves - freezer	3
Reversible door hinge	Yes