



INNOVATION

- Patented Pedestal Star® Burner with QuickClean Base® designed for easy surface cleaning and superior heat spread for any size pan
- Powerful 22,000 BTU (NG) burner (front right)
- Precision simmering capabilities as low as 100°F (375 BTU) with 4 ExtraLow® Simmer burners
- SoftClose® hinges for ultra smooth closing of the oven door
- Cleans both ovens simultaneously in just 2 hours

PERFORMANCE

- 18,000 BTU (NG) Star® Burners
- Titanium surface non-stick, rust-proof cast-aluminum griddle and grill, removable for easy clean-up
- Electronic oven display interfaces to cook timer, CookControl™ meat probe and preheat status with audible alert
- Full featured small oven with convection, broil, self clean and CookControl™ meat probe
- Powerful, 8-pass bake and broil elements in large oven and 6-pass elements in small oven
- Third Element Convection offers precise airflow for cooking on multiple levels without flavor transfer
- Large oven 5.7 cu.ft.-accommodates commercial sheet pan plus 2.5 cu.ft. in small oven
- Full Access® telescopic racks, integrated easy-grip handle
- Six rack levels in each oven for multiple item cooking
- Star-K Kosher certified

DESIGN

- Bold Professional design
- Pinhole and panel lighting concepts provide functional and stylish aesthetics
- Restaurant style metal knobs

- Professional style, continuous cast iron grates
- Continuous porcelain, easy to clean cooking surface
- Hidden bake element makes clean-up one smooth surface
- Large oven door window for maximum viewing
- Powerful halogen lighting illuminates the oven cavity
- Signature blue indicator lighting

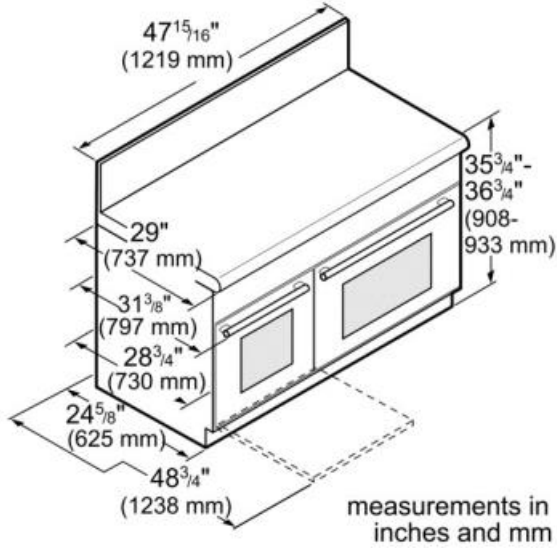
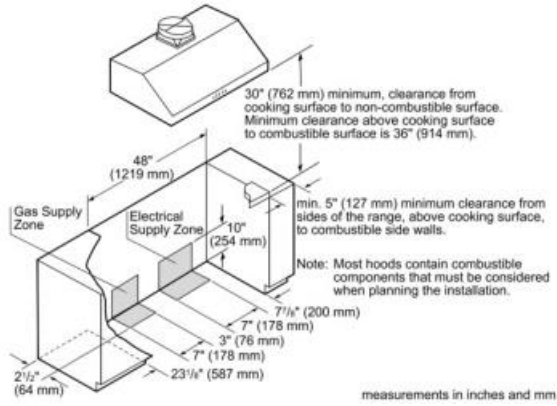

Amps (A)	50
Frequency (Hz)	60
Gas type	Natural gas 15 mbar (USA)
Approval certificates	CSA
Temperature control	No control of the temperature
Time control	No
Location of 1st heating element	front left
Included accessories	1 x nozzle set for liquid gas, 1 x island trim, 1 x grill plate, 1 x Broiler pan, 1 x broiler pan small, 2 x telescopic rack - small, 3 x telescopic rack, 2 x temperature sensor
Power of 1st heating element (W)	5.27
Location of 2nd heating element	center left
Location of 3rd heating element	back left
Location of 6th heating element	center right